

PSIG 2005

Expert Alarm System

Michael Bryant, Florida Gas Transmission, Søren Hvidbjerg, Energy Solutions International, Rod Dodson, Florida Gas Transmission

Copyright 2005, Pipeline Simulation Interest Group

This paper was prepared for presentation at the PSIG Annual Meeting held in New Orleans, Louisiana, 26 October – 28 October 2005.

This paper was selected for presentation by the PSIG Board of Directors following review of information contained in an abstract submitted by the author(s). The material, as presented, does not necessarily reflect any position of the Pipeline Simulation Interest Group, its officers, or members. Papers presented at PSIG meetings are subject to publication review by Editorial Committees of the Pipeline Simulation Interest Group. Electronic reproduction, distribution, or storage of any part of this paper for commercial purposes without the written consent of PSIG is prohibited. Permission to reproduce in print is restricted to an abstract of not more than 300 words; illustrations may not be copied. The abstract must contain conspicuous acknowledgment of where and by whom the paper was presented. Write Librarian, Pipeline Simulation Interest Group, P.O. Box 22625, Houston, TX 77227, U.S.A., fax 01-713-586-5955.

ABSTRACT

Florida Gas Transmission (FGT) has created an Expert Alarm System by combining SCADA data, model data, and model logic to produce integrated Gas Control alarms for the gas controllers.

The EAS was implemented to provide suggestions/alarms to the gas controller as to how the system could be run more efficiently and how to avoid certain potentially undesirable situations on the pipeline.

Typically these alarms are created after evaluation of several variables such as suction/discharge pressures, system line pack, control valve set points, regulator set points, and delivery load for a given area. This information would probably be correctly evaluated by the gas controller if he had plenty of time to consider all variables; however, the EAS system provides suggestions/alarms that are helpful especially when the gas controller is dealing with multiple pipeline situations.

The system uses a straight forward approach to accomplish its goals. The software logic is implemented as part of FGT's existing pipeline simulator tools using both model data and SCADA measurements as input. The generated alarms are delivered to the SCADA system for display with all other SCADA produced alarms.

This paper will present some of the benefits of implementing a system like the EAS. We will give examples of the logic EAS utilizes and compare this with the process a gas controller

would have to go through to come to a similar conclusion.

INTRODUCTION

The FGT Real-Time model & Expert Alarm System (EAS) were both co-developed by FGT Gas Control engineers and Energy Solutions International engineers.

Very advanced expert systems currently exist in the market. The EAS project was very careful not to become anything more than a straight forward modest technical advance that was clearly beneficial. Often with this type of project there is the temptation to try to create a system that does "everything". This project just tries to create very helpful suggestions. EAS does not attempt to run the pipeline system for the gas controller.

FGT has successfully been using Real-Time models to help the Gas Control department run the pipeline system more efficiently. The Real-Time model has allowed Gas Control to study pipeline and horsepower outages to determine how to most efficiently run and schedule the pipeline during these abnormal operations. The Real-Time model has also allowed the Gas Control department to study the FGT system in normal operating mode so that smarter decisions could be made in terms of day-to-day operations.

The Real-Time model has extensively been used by the managers and engineers that work in the Gas Control department, but the gas controllers have not used the Real-Time model very much. The EAS is a step towards Real-Time models and the information available in models being used throughout the day by gas controllers.

The SCADA alarms that are produced by the FGT system serve their purpose well; however, there are many operational situations where the gas controller needs to be alerted to a critical situation even though no SCADA alarms have been generated. Often times if pressure "B" exists and flow "A" exists then the gas controller needs to be forewarned of an upcoming situation.

The EAS was designed to be a smart step forward in the usage of SCADA data and model data to present the gas controller

with the best available suggestions for them to do their job. The EAS has several fairly sophisticated alarms that perhaps point to how this type of a system could be used as a more advanced tool in the future. Some of the EAS alarms use current SCADA and model data to determine if a Look-Ahead model scenario should be automatically launched. Based on the outcome of the automatic analysis an alarm is produced for the gas controller giving some forewarning of possible upcoming issues on the system.

The EAS project has been a small budget project, but upon initial movement into production it has shown itself to be very useful. One of the best indicators of the success of this system is that gas controllers suggest additional ideas for how more EAS alarms could be created. Many times modeling systems are viewed as a threat to the gas controller – “is this system supposed to replace the gas controller?” The EAS has always been seen as a way to help the gas controller with their increasing job responsibilities.

MOTIVATION FOR BUILDING THE EAS

The FGT gas controllers’ responsibility has grown significantly over the past 7 years. FGT has undergone several pipeline expansions. During this time period FGT’s capacity has grown from 1,450 MMBtu/d to 2,150 MMBtu/d. The facilities managed by the gas controller have grown significantly; however, the Gas Control staff has not grown significantly. EAS was created to help the gas controller with this increase in responsibility.

Many of the alarms were designed not only to help the gas controller to manage the system but to manage the system more efficiently. Several of the alarms were designed to notify the gas controller when more fuel efficient modes of operation were available.

The primary goal of the EAS project is to help the gas controller; however, the EAS project proved itself to be a natural way to address several efficiency issues on the pipeline.

USEFUL – NOT ANNOYING – ALARMS

Those involved with the EAS project have tried to be very respectful of not wasting the gas controllers’ time; thus, an additional goal of the EAS project was to ensure that the alarms that are produced by the system are useful to the gas controller. This may seem to be an obvious goal, but many times when creating alarm criteria usefulness takes a second seat behind “consistency” or “safety”. Many extra logic steps were put into each alarm check to ensure that nuisance alarms are not created. For example, if an alarm has been generated in the last hour or two, then another alarm of the exact same type will not be generated.

FGT PIPE DESCRIPTION

With over 5,000 miles of pipe and over 450,000 horsepower on the system, the FGT pipeline has a forward haul delivery capacity of approximately 2,150 MMBtu of natural gas per day. FGT’s peak day delivery record is about 2,800 MMBtu. The FGT system is characterized by the pipeline’s dynamic swings in linepack caused by delivering the majority of its gas to electric generation power plants. Unlike many other North American pipelines, the system’s peak deliveries are during the summer to meet cooling loads. See *Figure 1* for an overview of the FGT pipeline.

FGT REAL TIME MODEL & EXPERT ALARM HISTORY

Initial System

The history and development of the EAS project is tied to the history and development of the FGT Real-Time model. The original goals of the Real-Time model project were to develop a tool to help the Gas Control department better perform their job. The Real-Time model project achieved its overall goal by helping the Gas Control department run the system more efficiently; however, the gas controller usually does not have time to run flow studies while managing the pipeline. With this in mind the EAS was designed as a way to conveniently put more advanced analysis in front of the gas controller.

The modeling project began shortly after FGT increased its delivery capacity of the pipeline from 925 MMBtu/day to 1,450 MMBtu/day. Overall system complexity increased with the addition of a parallel third line operating at higher pressure and operating with turbine compressors instead of the traditional reciprocating compressors. Furthermore, FGT’s pipeline has no market area storage, but still faces the challenge of a high load factor market with a large percentage of the market customers using gas to meet electric generation peaking loads. Due to the increase in delivery capacity and the challenging market demands, FGT decided to build a Real-Time transient model to give those in the department a tool to assist in meeting the challenges of operating a fairly difficult pipeline.

Engineering or off-line simulation models have been successfully used for many years; however, in the past real-time or on-line dynamic models have proven to be fairly difficult to implement successfully. FGT achieved success in its Real-Time model by first having the Gas Control department build and use the model to manage every day problems and outages encountered on the pipeline before attempting to use the model to optimize the system.

Project Timeline

Following is an approximate timeline of the implementation of the Energy Solutions model, the related events, & the related improvements:

March '95 - Expansion of pipeline capacity to 1460 MMBtu/d completed. The decision was made to proceed with the selection of a Real-Time model vendor.

September '96 - Modeling project completed.

December '96 - Model is used to help with outage coordination effort of several major pipeline jobs.

February '97 - Model is used to determine more fuel-efficient operational modes for winter operations.

May '97 - Model used as a tool to analyze how to optimize horsepower configurations to improve overall throughput.

July '97 - As a result of model studies, the operational modes of several compressor stations are changed. Sustainable market deliveries are increased 2% above previous levels.

June '98 - With the combination of compressor station optimization and improved linepack management, sustainable throughput is increased another 2% while at the same time increasing total system reliability. Significant fuel usage reduction also achieved.

October '98 - Development begins on the model to create a gas control trainer.

January '99 - Yearly total fuel usage charge to market area customers for 1998 shows a 12% reduction compared to previous years even though delivery levels remained the same.

February '99 - Gas control trainer is completed.

March '01 - Expansion of pipeline capacity to 1,660 MMBtu/d completed. Pipeline model expanded along with expansion of pipeline. Model used to study most efficient modes of operation.

March '02 - Expansion of pipeline capacity to 2,050 MMBtu/d completed. Pipeline model expanded along with expansion of pipeline. Model used to study most efficient modes of operation.

March '02 – EAS Phase I project started in an effort to help Gas Control staff handle increased responsibility of managing a larger throughput system.

October '02 – EAS Phase I completed.

March '03 - Expansion of pipeline capacity to 2,130 MMBtu/d completed. Pipeline model expanded along with expansion of pipeline. Model used to study most efficient

modes of operation.

October '03 – EAS Phase II project started. This phase covers more stations and more operational scenarios.

June '04 – EAS Phase II completed.

SYSTEM DESCRIPTION

The EAS takes advantage of some of the existing model infrastructure at FGT, in particular the modular and generic nature of the model tools. This has made the EAS straight forward to implement.

The EAS requires a number of analog and digital SCADA inputs as well as inputs from the Real-Time and Look-Ahead models. These are being provided using the same interface as the other SCADA points required by the model.

The alarms produced by the EAS are sent to the SCADA system for display on the regular SCADA alarm page used by the operators. Again, the existing interface to SCADA was used.

The EAS is primarily using two types of model inputs, pipeline error indications and calculated pressures. These model inputs are discussed in more detail below. Since the EAS is a custom module implemented in the model environment, it is able to read this data directly from the real-time model database.

The system diagram is shown in *Figure 2*.

IMPLEMENTATION

The EAS was implemented in cooperation between FGT Gas Control and model programmers. The Gas control team described the expert operational pipeline knowledge in the form of flow chart diagrams, some of which are shown in this paper.

The logic in the diagrams was implemented as a customer specific module in the FGT Real-Time modeling environment. This required writing one code module and creating two configuration templates. In FGT's version of the modeling tool the data input to the configuration is entered into Microsoft® Excel spreadsheets.

The project implementation required some support from the FGT SCADA team in defining new SCADA points. These points are used for holding the alarm indications coming from the EAS. Each point has an associated alarm which is triggered when the value becomes 1 and cleared when the value becomes 0.

ALARM EXAMPLES

Increase/Reduce Horsepower

Horsepower management was one of the first areas where the EAS was designed to aid the Gas Control department. With extensive supervision of various setpoint parameters, the EAS alarm logic was developed to recognize situations where it would be advantageous or increase efficiency to start up additional compressor units. The EAS system continually monitors for situations that can easily come upon gas controllers on a busy day such as a compressor gradually reaching its discharge pressure setpoint and beginning to gradually slow back resulting in lower, less efficient throughput. The EAS is ideal for detecting situations such as this.

The diagram in *Figure 3* shows the logic for determining if an additional reciprocating compressor unit needs to be brought online. An initial check for available units at the beginning of the process helps to minimize the number of nuisance alarms by preventing the gas controller from receiving alarms suggesting that non-existent units be started up. As with logic discussed previously, the logic for this alarm monitors market conditions and seeks to maximize throughput while also protecting the compressor station itself against conditions that would be detrimental such as a high discharge pressure or temperature.

Line Break Operator

The majority of compressor stations on the FGT pipeline system discharge gas downstream into parallel lines. Occasionally when there is a large pressure fluctuation on one of these lines such as when a compressor station goes down, it is possible for the line break operator to close although an actual pipeline rupture has not occurred. When this happens it is possible for the line break operator to remain closed afterwards without being noticed. This is especially true when the pipeline is not delivering at full capacity and the second parallel line has room to accommodate the additional gas that would have otherwise flowed down the first line. The purpose of the Line Break Operator Alarm is to notify the FGT gas controller when this situation may be occurring.

The flow chart in *Figure 4* shows the Line Break Operator Alarm logic. The Real Time pipeline model employed by FGT calculates Tuning Values for each of the mainline compressor stations. These Tuning Values reflect the degree to which the model calculated pressures compare to the actual SCADA pipeline pressures. The Tuning Values themselves correspond to the volume of gas added or taken away from the system at each compressor station to keep the model in balance. The logic for this alarm relies on the use of these Tuning Values to determine that a line break operator may have closed.

The Line Break Operator Logic looks at a compressor station along with its neighboring upstream and downstream stations. The *Figure 4* flow chart shows a case where FGT compressor stations 75, 8, and 9 are being considered. The first step in the logic checks is to see if the Tuning Values for the stations of interest are very high (>50), indicating a large inaccuracy with a calculated pressure. The next step then checks the Tuning Values across the rest of the system to make sure they are reasonably low (<30), thereby reflecting that the modeling system calculations are close to actual pipeline conditions. The logic in these two steps helps to ensure that although the Tuning Values across the compressor stations of interest indicate a possible problem with that region of the pipeline, the remainder of the model closely reflects SCADA system values before the logic can continue. Occasionally, after the model has been restarted or key SCADA inputs are lost such as when major communications outages occur, the calculated model pressures compare poorly with actual pipeline pressures. In these cases an alarm should not be triggered since it could easily be a false alarm.

Once the logic has determined there is a potential problem within a group of compressor stations, it will check for an excessive pressure drop between upstream and downstream stations and issue the appropriate alarm to the gas controller when all these conditions are met.

Although this alarm was initially developed to detect closed line break operators, the logic will also detect other sources of excessive pressure loss such as accumulation of sludge, buildup of contaminants in the pipe, or any other restriction. Because the logic driving this alarm actually detects excessive pressure loss due to any restriction, not just closed line break operators, it is now used on compressor stations regardless of the number of discharge lines.

Fort Myers Low Pressure

The Fort Myers delivery point is one of the largest and most critical on the FGT system. The Fort Myers meter is situated at the far south end of the Fort Myers lateral which is in turn situated at the south end of FGT's West Leg. Because of the distance involved in delivering gas to Fort Myers, the pipeline must be managed in a very proactive fashion to maintain adequate pressure at Fort Myers. The purpose of this alarm is to indicate a potential future problem with the pressure at Fort Myers. The diagram in *Figure 5* illustrates the Fort Myers Low Pressure Alarm logic. For the first step a timer sets the alarm logic frequency at thirty minute intervals.

The next several steps check for a moderately low line pressure at the end of the Fort Myers lateral, a high total West Leg delivery, and a decreasing pressure at Fort Myers. If all of these conditions are met, then pipeline conditions are such that the potential exists at Fort Myers for the lateral pressure to

drop to critically low levels if current market loads continue.

At this point, the logic initiates the Look-Ahead model. The Look-Ahead model is able to take current pipeline conditions and extrapolate them to a set time into the future based on current loads. Obviously, with a dynamic pipeline system such as FGT's, this extrapolation is only good to a certain point when total market loads can vary by as much as 200% or more during the course of a day. However, extrapolations of two hours are accurate enough to alert gas controllers to impending low pressure conditions. For this alarm, the Look-Ahead model runs to simulate pipeline conditions up to two hours in the future. It stops when either a Fort Myers lateral pressure of less than 600 psig is projected or the two hour extrapolation limit is reached. If the pressure is projected to drop below 600 psig within the next two hours an alarm is issued to the gas controller indicating this information along with the projected time at which this might occur.

If the alarm is issued, appropriate action can be taken by the gas controller. Examples of this action could range from bringing up additional compression to communicating with customers that may be taking excessive amounts of gas at particular locations.

Jacksonville Lateral

FGT provides natural gas to the Jacksonville area in Florida through its Jacksonville lateral. This lateral connects with the FGT mainlines at Station 16 in Brooker, Florida. A unique feature of the Brooker compressor station is that the Jacksonville lateral can be fed from either the discharge or suction side of the station. This action is accomplished by reconfiguring valves located at the station and can be done remotely from the Gas Control system in Houston. When the loads on the Jacksonville lateral are low and the lateral pressures are adequate, the lateral can be fed from the suction side of Station 16 to maximize efficiency. Conversely, if the Jacksonville loads are high or the lateral pressure is low, station valves can be reconfigured to feed the lateral from the discharge side of the station.

The diagram in *Figure 6* shows the Jacksonville Lateral Alarm logic. The first step in the logic is to determine the current station configuration regarding the Jacksonville lateral – is it being fed from the discharge or suction side of the compressor station? Beyond that point there are two branches in the logic, each of which checks current operating conditions and determines whether or not the current configuration should be changed. If the current station configuration is set to where the lateral is being fed from the discharge side of the station the logic next determines if current conditions will allow the lateral to be switched to the suction side. Because the station discharge pressure and station spread will both increase if the lateral is switched back to suction these two values are examined to make sure there is room for the switch to occur. If this is the case the Jacksonville lateral pressure is

examined to make sure it is adequate. If the logic makes it to this point, a final check is made to make sure the station will not start recycling excessive amounts of gas if the lateral is switched to suction. The overall thought behind this logic is that it is more efficient when the lateral is run from the suction side of the station.

The other logic branch for this alarm is used if the Jacksonville lateral is currently being fed from the suction side of the station. This portion of the logic determines if the lateral needs to be switched to the discharge side of the station. It first checks the spread across the compressor station to see if a switch is even possible. It then checks the pressures on the lateral. If they are not adequate an alarm will be generated that indicates that the lateral should be switched to the discharge side of the station.

The logic for this alarm is designed to protect the station first, then to maximize flow down the mainline, but when necessary to maximize flow down the Jacksonville lateral.

Spillover/Recycle Station

In the major throughput portion of the pipeline, FGT has five stations (stations 11 through 15) that all have three parallel lines (24", 30" and 36"). The MAOP of the 36" line is 1200 psig whereas the other lines have an MAOP of 975 psig. At each station FGT has the option of "spilling over" gas from the high pressure line to the lower pressure lines. For this reason these compressor stations are sometimes referred to as spillover stations. The required amount of gas spillover depends on conditions at adjacent stations as well as line pack and supply/delivery load. At each of these stations gas turbine driven compressors are used on the high pressure 36" line. The more traditional reciprocating type compressors are used on the lower pressure 24" and 26" lines. An exception to this configuration is station 13 at Caryville where large electric motors are used in place of gas turbines.

One example of a situation where gas may be spilled over would be where the station spread across the reciprocating side of the station is dropping to unacceptably low levels, but where the extra throughput of an additional reciprocating unit is not necessary. If there is adequate pressure on the turbine side of the station the spillover can be utilized to spill gas over to the reciprocating side of the station, thereby raising and maintaining the station spread at acceptable levels.

Another case might be where the high pressure 36" line is running at levels close to MAOP and rising, but where the lower pressure 24" and 26" lines still have room for additional gas. In this case, the station spillovers can be used to send gas to the lower pressure lines and consequently relieve some of the pressure on the 36" line.

The diagram in *Figure 7* illustrates the spillover logic for FGT's station 12. It can be seen from this diagram that many

factors have to be considered in the operation of this station. Rather than examining each item shown in the diagram in detail, a general overview of the alarms will be discussed.

The logic shown in the diagram evaluates various parameters associated with compressor station operations to issue an alarm suggesting various actions such as adjusting the station spillover setpoint, swinging or shutting down reciprocating compressor units, and adjusting turbine compressor setpoints. The main thrust of the logic associated with this type of alarm is maximization of station throughput to meet market demand while concurrently protecting the station from conditions which could threaten either a station shut down or physical damage to the station.

Although the Spillover Station Alarm logic modules for each of the spillover stations are very similar, they are each tailored to meet the unique arrangement of their prospective stations. For example, parameters from nearby meter stations may be evaluated along with the compressor station parameters to minimize negative impact to the meter station area. In addition to protecting the immediate station, parameters from both the upstream and downstream stations are examined to minimize negative impact to those stations as well.

Meter Station Check

The FGT system currently has over 400 gas flow measurement stations for receipt and delivery points located along the length of its pipeline. When chromatograph and compressor station RTU's (Remote Terminal Units) are included, the total number of measurement stations increases to nearly 500. Properly monitoring this number of measurement stations requires a tremendous amount of time and energy. The sooner a problem is detected, the less the impact will be.

FGT's flow measurement stations deliver gas to a wide range of customers in terms of total volumes and load patterns. Total daily volumes range from less than 50 Mcf/d for small customers to over 300 MMcf/d for large power plants. Several meter types are used such as orifice, turbine, and ultrasonic meters. These are set up across the Florida Gas system in a variety of configurations. Several EAS alarms have been developed to aid in detecting errors with these flow measurement stations.

The alarm that was developed for multi-run orifice meters is shown in *Figure 8*. This particular meter run implementation is designed to operate in a fashion such that the runs open in consecutive order and then close in reverse consecutive order. In other words, they open in the order of 1,2,3 then close in the reverse order of 3,2,1. It is important that this order be maintained. For example, if for a two run meter station, the second run registers flow but the first run does not, a couple of problems are likely to be occurring. The first is that there is a mechanical problem preventing the first run from operating.

All gas flow through the meter is being properly measured, but the desired flow rate may not be achievable if both runs are required. A second problem would be where the first run is actually flowing but the orifice meter is not registering flow for some reason. In this case, the required amount of gas may actually be flowing, but it is not being recorded. Either case can quickly cause major operational or accounting problems and generally requires immediate attention.

The logic for the Meter Station Check Alarm monitors multi-run meters on the system to make sure the proper run order is maintained. Because this type of problem can easily be overlooked by gas controllers on a large system, the EAS can be a valuable tool for detecting problems such as this in a timely fashion.

Station 18 Suction Valve Check

The Florida Gas Transmission system began transporting gas in 1959. Much of the original pipe is still in service. The lowering of the MAOP of some older pipe has been necessitated in areas where population growth has encroached upon the pipeline. At compressor stations 18, 20, and 21 control valves are used to protect the older lines on the suction side of the station. When the suction pressure at one of these stations approaches the MAOP of the lower pressure line a control valve automatically closes to protect the older line's MAOP. In the case of station 18 the reopening of the valve must be performed manually. Depending on pipeline conditions and market rates it may be several hours or several days before this valve can be reopened. It is a possibility in a case like this for a gas controller to forget to reopen the valve.

The diagram in *Figure 9* shows the EAS alarm logic used to monitor the suction valve for station 18. The logic first checks the valve status using a discrete point from the SCADA system. If the status indicates that the valve is not closed an additional check is performed, in case the discrete point is giving us a false reading, to see if the pressure difference between the two suction lines is greater than 15 psi. If the pressure difference is greater than 15 psi the valve is probably closed. After this point an additional check is made to make sure the pressure on the higher pressure line is sufficiently low enough to allow the valve to be opened up without having to close again a short time later.

If the suction valve is determined to be open, logic for this alarm calls the Line Break Operator routine discussed earlier to check for a closed line break operator or some other obstruction.

BENEFITS/CONCLUSION

In the History portion of this paper are references as to how the Real-Time model was used to increase deliveries and reduce fuel usage. The financial benefits are obvious for these accomplishments. The primary goal of the EAS was to provide intelligent alarms to gas controllers that leverage the knowledge of the FGT system acquired over the years by the Gas Control group. This important goal was accomplished. If financial benefits must be measured then it should be considered that the FGT Gas Control department has about the same number of employees as it did before the pipeline capacity expanded by 50%.

Many of the EAS alarms address efficiency issues. These efficiency issues generally relate to fuel efficiency, although some relate to poor operating conditions for compressors ("wear & tear" costs). No attempts have been made to measure actual fuel efficiency gains or operational cost reductions; however, with the help of the Real-Time model and EAS it is reasonable to estimate that the pipeline system will continue to be operated efficiently by the same staff level even as more delivery capability is added to the system.

As a final thought, the EAS project represents to FGT the continued progressive evolution of the usage of computer systems in the Gas Control environment. SCADA systems are clearly an efficient way to bring a large amount of data in front of gas controllers. SCADA alarms are vital to safe operation. Real-Time model systems are powerful tools for analysis. Look-Ahead models are great for analyzing future events. The EAS efficiently combines data from these different systems to provide logical efficiency alarms that did not exist before.

BIOGRAPHY

Michael Bryant has a Bachelor of Science in Mechanical Engineering from Texas A&M University in College Station,

Texas. He has worked in the oil and gas transportation industry since 1991. He worked briefly as a consultant for FGT and then as an FGT Gas Control engineer for FGT since 1994. He is currently the Director of Gas Control & Optimization for FGT.

Søren Hvidbjerg has a master's degree in computer science from the University of Aarhus in Denmark. He has been employed by Energy Solutions since 1988 and thereby gained significant experience in the oil and gas industry. He has worked both in the project implementation and software development areas, lately focusing most of his effort in the development of a state of the art GUI.

Rod Dodson has a Bachelor of Science in Petroleum Engineering and a Master of Science in Management Information Systems from Texas Tech University in Lubbock, Texas. He has worked in the oil and gas industry since 1983. He previously worked for Electronic Data Systems supporting FGT Gas Control systems. He has been employed by FGT as a Gas Control Engineer since 2003.

REFERENCES

ACKNOWLEDGEMENTS

We would like to thank the following FGT personnel for helping with the design and implementation of the system and for kind help in preparing this paper:

Jorge Villarreal
Steve Hearn
Stan Ryzinski
Ruben Rodriguez
George Margoliner

FIGURES

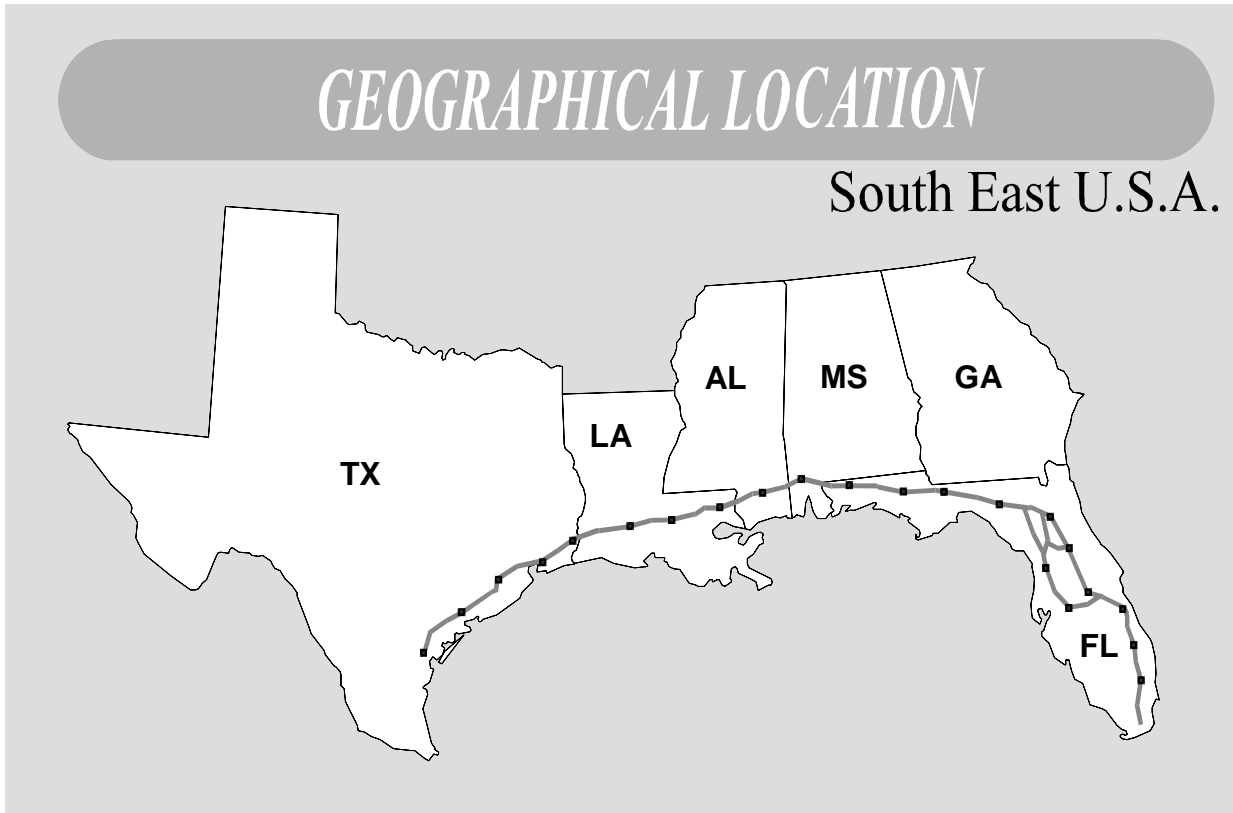

Figure 1. Florida Gas pipeline overview

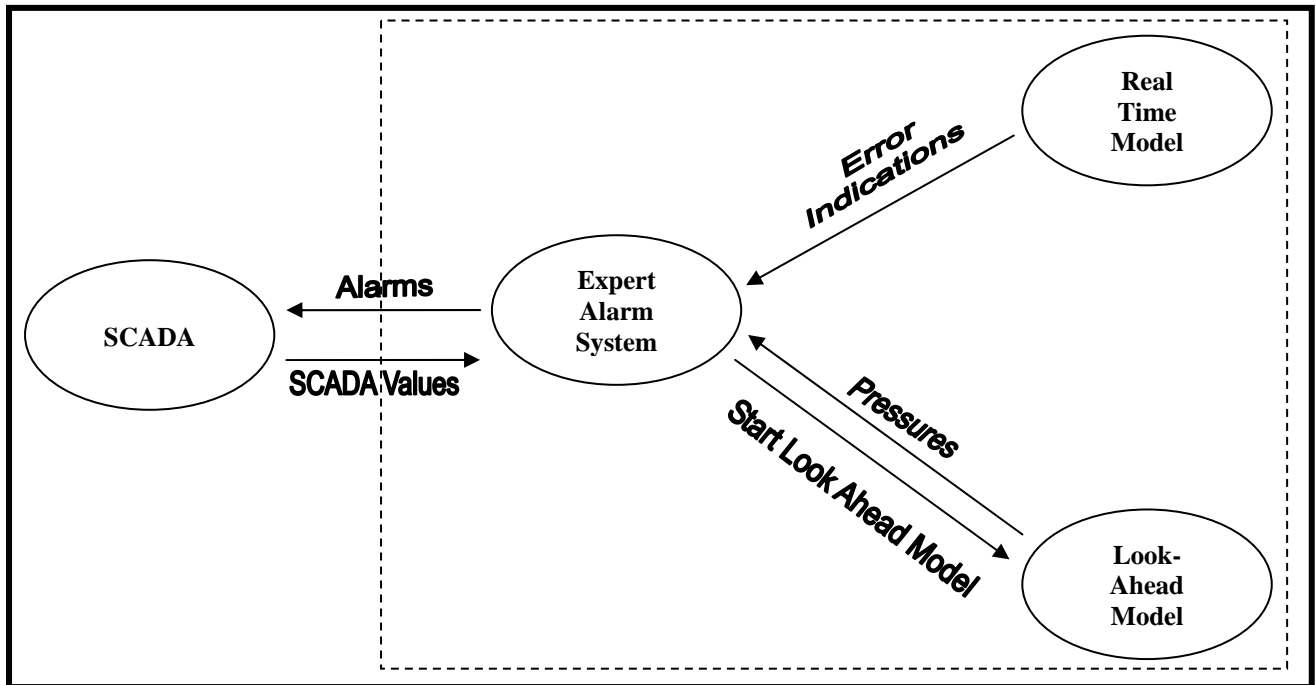

Figure 2. System Interfaces

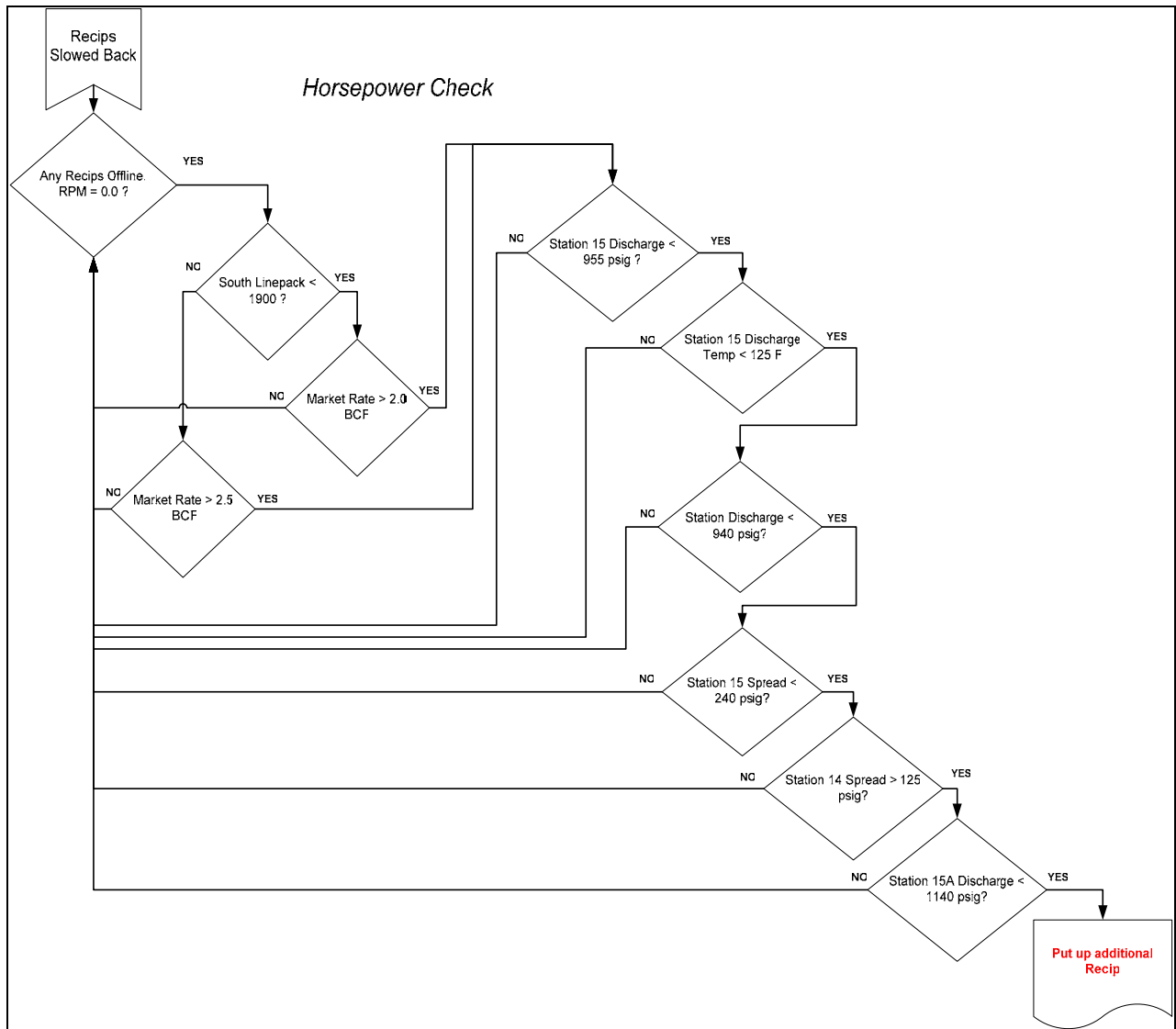

Figure 3. Additional horsepower required alarm

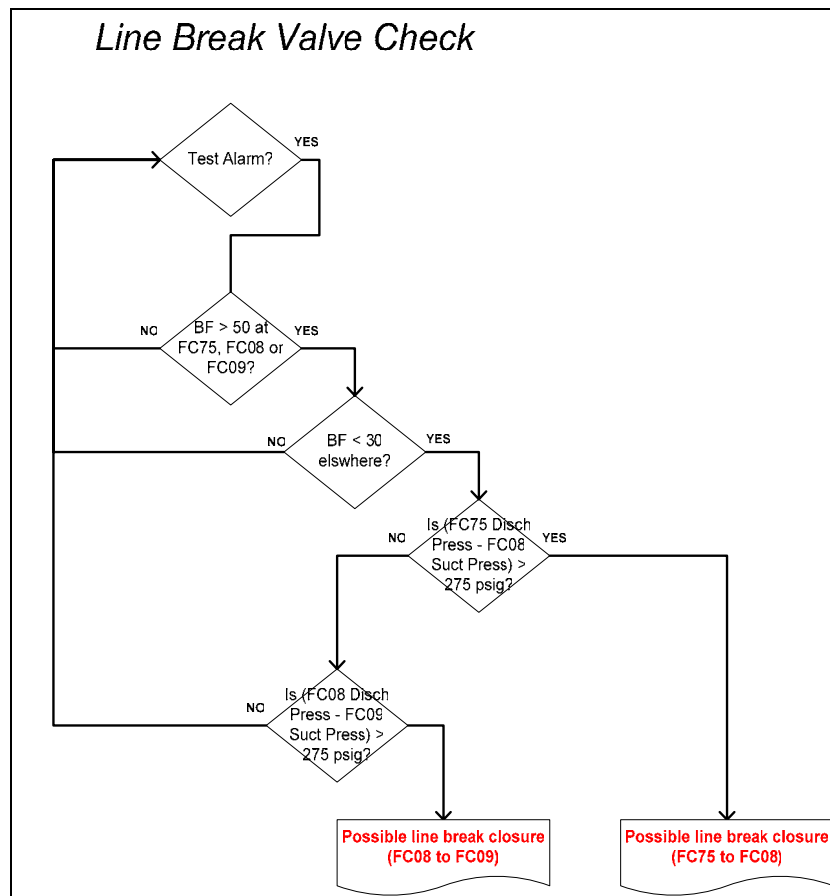

Figure 4. Line break operator alarm

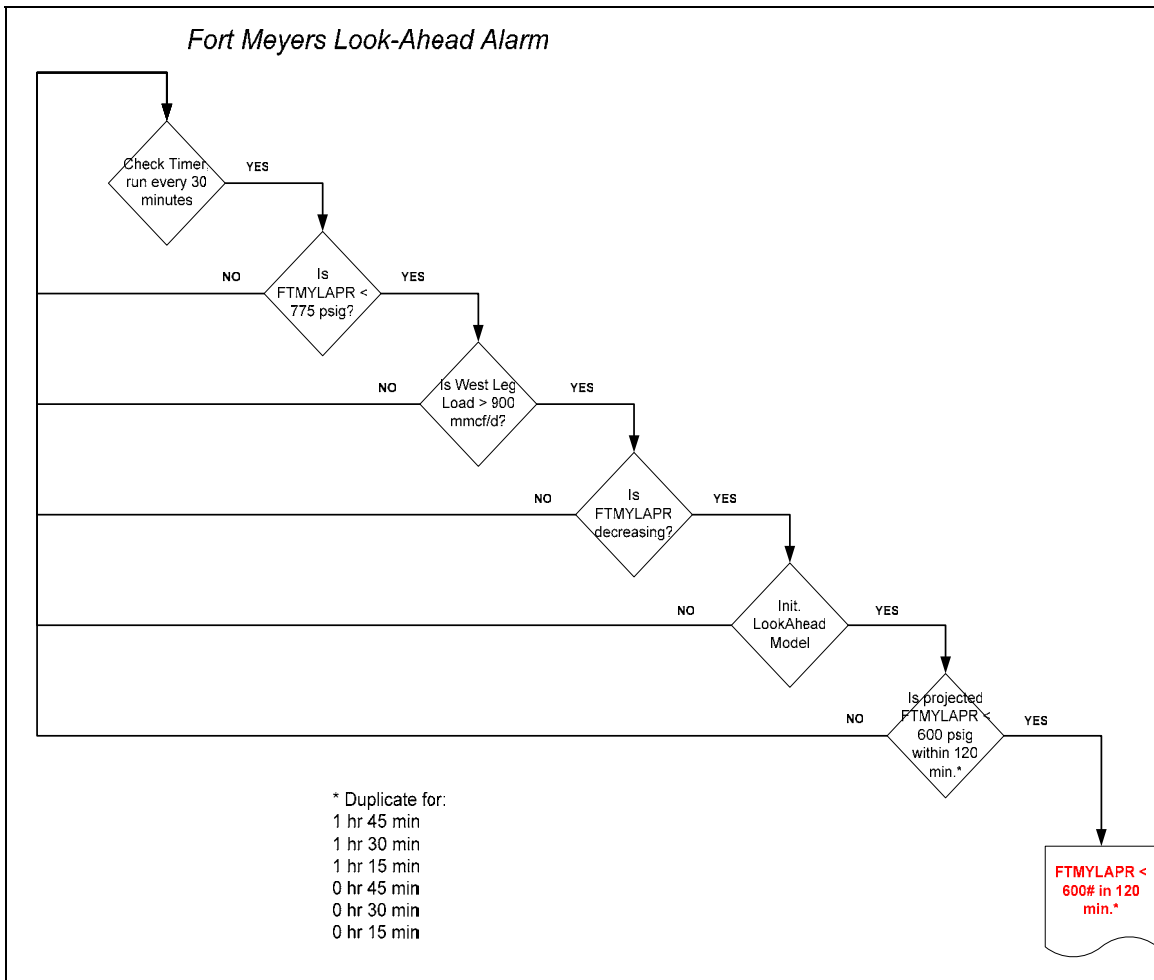

Figure 5. Fort Myers delivery pressure alarm

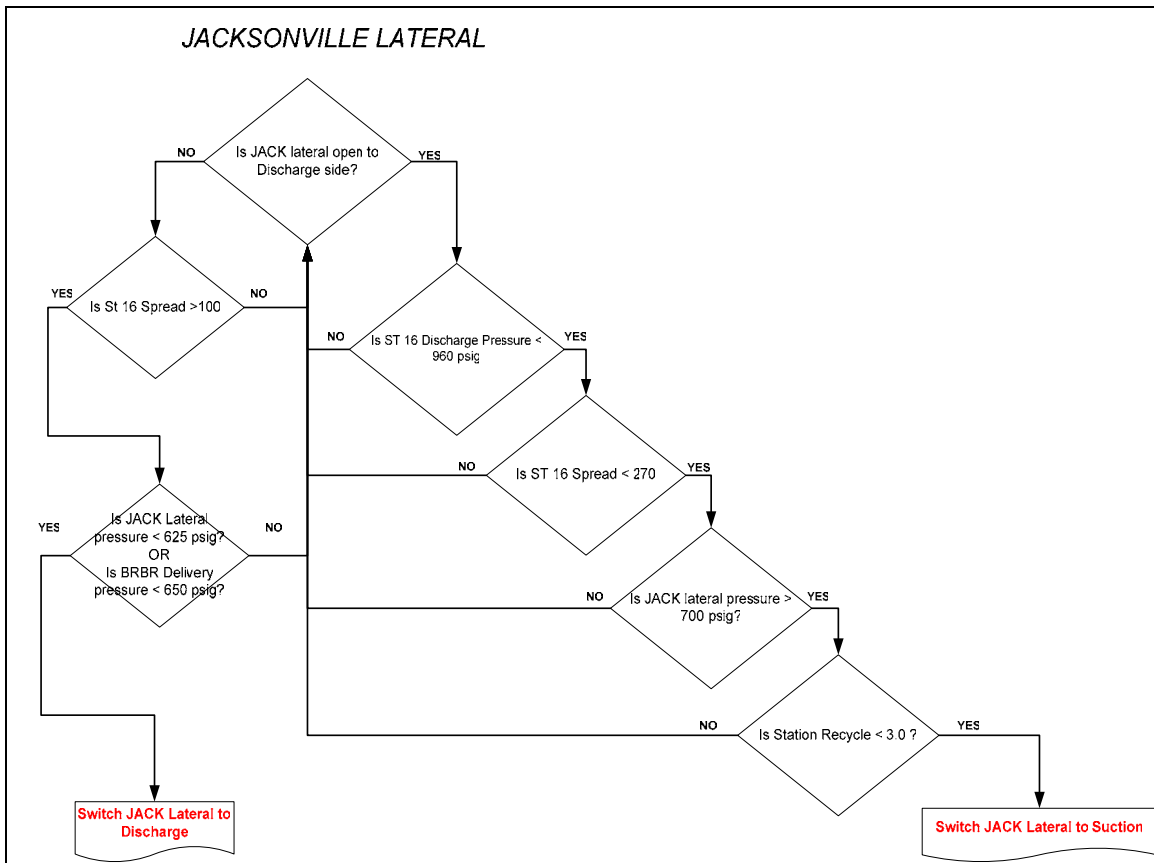

Figure 6. Jacksonville suction/discharge switch alarm

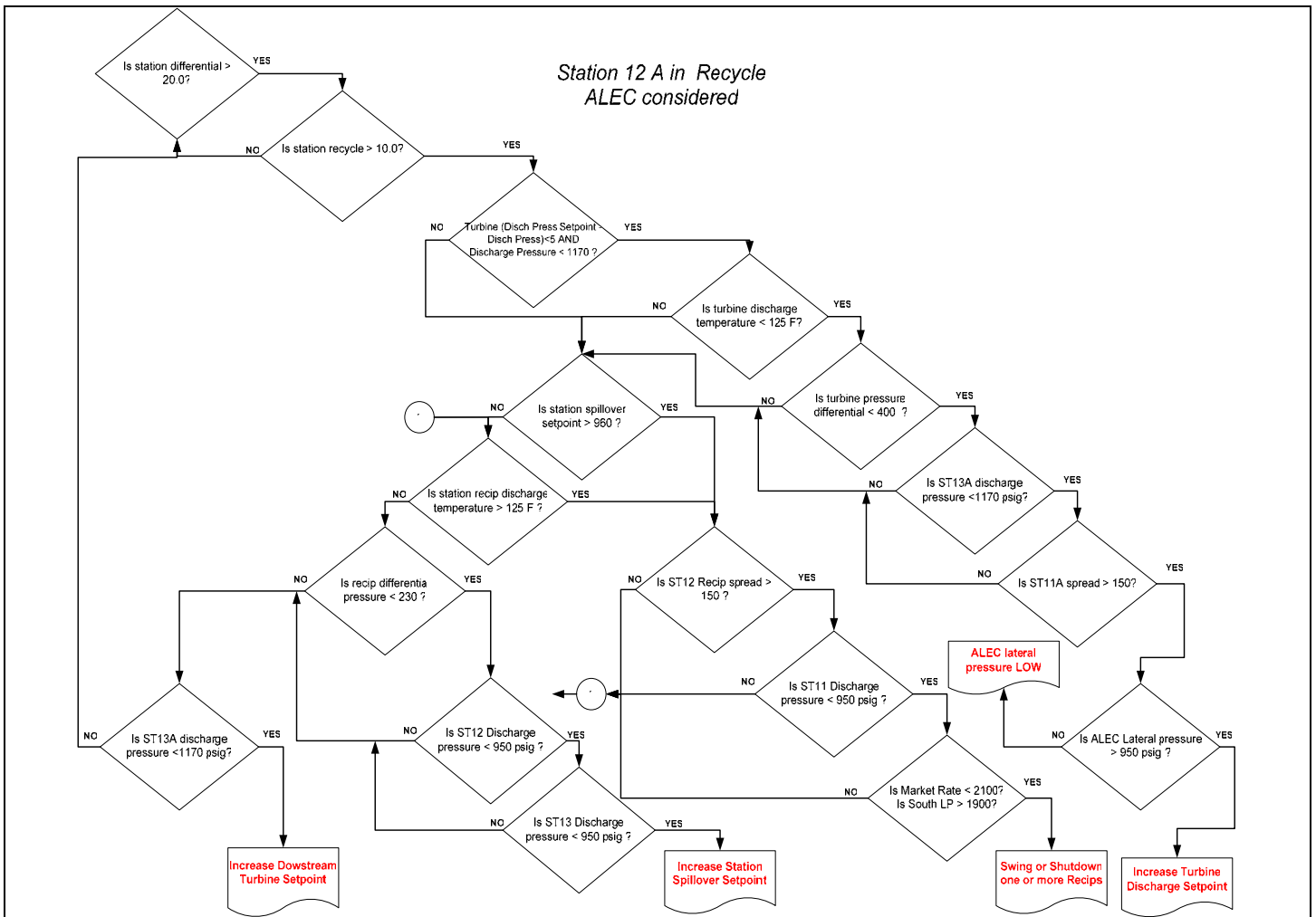

Figure 7. Spillover station alarms

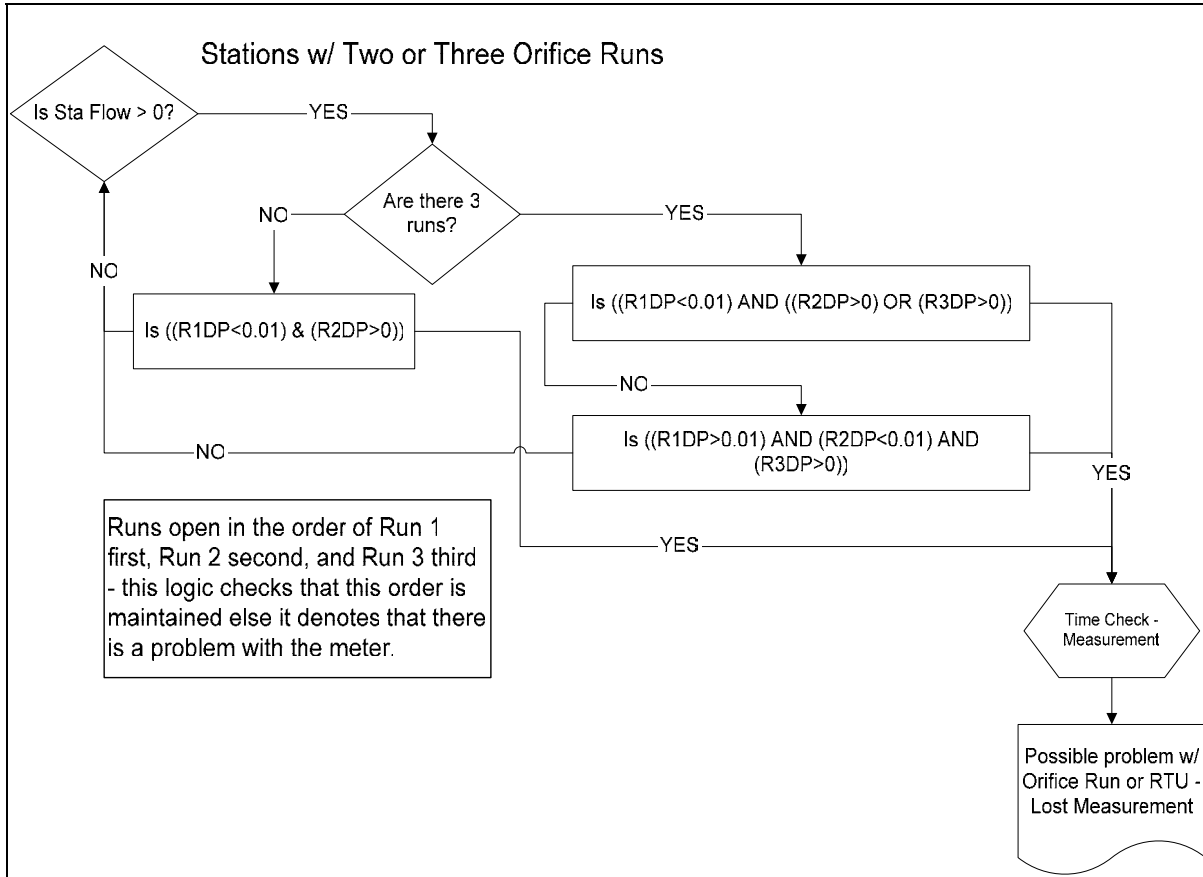

Figure 8. Meter station alarm

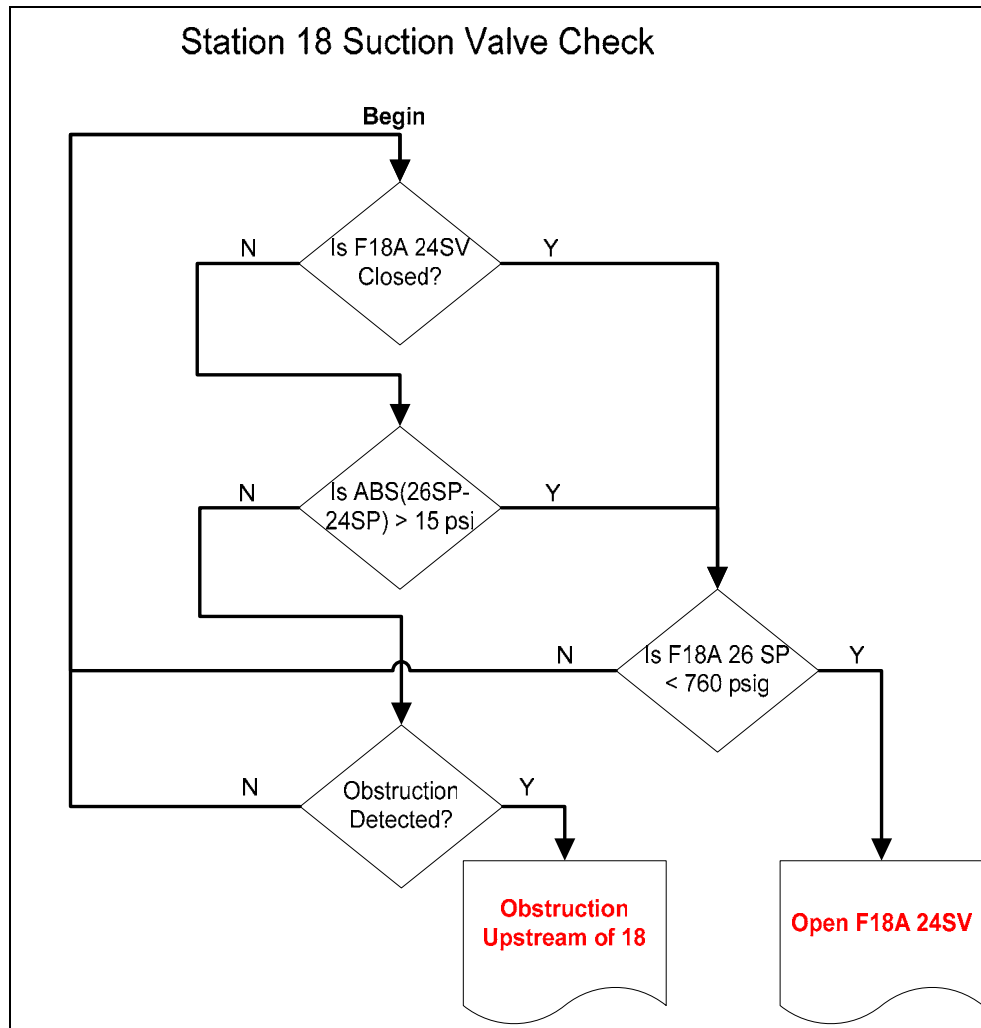

Figure 9. Station 18 suction valve alarm